



ELECTRICAL POWER SYSTEMS

From optimal design to operational excellence

- > Enhance your network reliability
- > Minimize the total cost of ownership
- > Secure your electrical environment
- > Extend the lifetime of your network equipment

COMPLEX ELECTRICAL POWER SYSTEMS

All grid operators and industry challenged

Operators of industrial and public electricity grids face an increasingly challenging task. They must guarantee the operational reliability of ageing and progressively more complex networks, all while saving on maintenance and exploitation costs.

More and more industries and public life rely on high performance electrical networks. Incidents and/or aberrations in quality often result in incalculable costs. These include, among other things, production downtime, damaged installations, financial penalties, loss of data, and ageing of critical components. Moreover, these do not take into account the many hidden costs such as harmonics that accelerate the ageing of transformers.

At the same time, operation of electrical networks is rapidly becoming more complex due to the accelerating rise of non-linear loads (such as power electronics) and decentralized energy resources.

Against the background of the increasing demand for lifetime extension and operational cost savings, it means a huge challenge for grid operators and asset managers.



EXPERT KNOWHOW AND SPECIALIZED SERVICES

From design to daily operations

Laborelec helps industry, the tertiary sector and grid operators achieve operational excellence within their electrical network. We advise on both the design and exploitation processes because we believe that the harmonious match between these two factors is paramount for maximum performance at the lowest cost.

WHAT DIFFERENTIATES US?

> **Our expertise covers all types of electrical networks.**

We are experienced with distribution grids and electrical grids for industry and the tertiary sector at low, medium, and high voltages.

> **Our recommendations aim to minimize total cost of ownership.**

All recommendations made come with a reliable cost/benefit analysis. We support you in making the right investment decisions without incurring extra or hidden operational or maintenance costs.

> **Our solutions are quickly realized and made to last.**

In the event of an incident, our team makes every effort to enable you to resume safe operations as rapidly as possible. They will always seek to unravel the cause so that they can help you avoid similar incidents in the future.

> **Our advice is firmly rooted on solid technical grounds.**

Our renowned ability to make accurate diagnoses is the result of state-of-the-art measurements, meticulous calculations, and advanced modelling tools, and our experience in correctly interpreting these results.

> **We provide you with solutions, not just measurement logs.**

We can call upon our vast expertise and decades of experience with complex electrical networks. When necessary, we can rely on our colleagues from other disciplines for correct diagnoses and effective recommendations.



OPTIMIZE YOUR CONCEPT

Include safety and continuity in the initial design

The best basis for a reliable, safe, and cost-effective exploitation is an optimal initial design of your electrical network. That means calculating the right dimensions of all parts as well as the best protection strategy. It also means keeping harmonic and asymmetric load flows under control and tuning a plant to maintain the quality of the local supply. Laborelec technical experts advise you on new networks and extensions in all development phases of your project. That includes a smooth handover to the exploitation team.

PRELIMINARY STUDIES AND DETAILED DESIGN

The initial design of your network should minimize investment costs without inducing unwanted exploitation risks or hidden operational costs. During our study of the design concept, Laborelec experts consider, among other things, expected maintenance costs, energy efficiency, safety risks, and ageing of key components in your network. Our advice includes:

- > Dimensioning (sources, cables, linear and non-linear loads, filters, etc.)
- > Electrical load flow simulation
- > Protection strategy
- > Immunization
- > Dynamic modelling
- > Harmonic load flow simulation
- > Main signalling influences
- > Zero measurement study
- > Thermal resistivity calculations for cables
- > Medium voltage component choice
- > Performance monitoring

SPECIFICATIONS

The price-driven purchase of electrical components, even when compliant with actual standards, can often not be the best option from the total cost of ownership perspective. Finding the optimal specifications for your network requires a unique depth of experience with complex networks and their specific components. You can rely on our manufacturer-independent advice on materials, best practices, and available techniques.



IMPLEMENTATION

Manufacturer defaults are not tuned to the specific design of your network or to the power quality of the distribution network. Before start-up, Laborelec audits all settings and tunes them for safe and reliable operation to your specific situation.



NEW LOADS

Integrating new loads into your network, especially non-linear loads, requires in-depth study and expertise. Laborelec calculates the optimal electrical protection and dimensioning parameters and determines how to maintain the power quality inside and outside your network. We advise you on the right design adaptations and immunization techniques.

HAND-OVERTO OPERATIONS

A correct and comprehensive hand-over procedure to the exploitation department guarantees continuity and safety during the operations to follow. Laborelec bridges the project team with the exploitation team by:

- > Validation measurements (power quality, including power frequency, supply voltage amplitude, flicker, supply dips/swells, voltage interruptions, unbalance, harmonics, interharmonics)
- > Permanent monitoring of power quality and performance
- > Validating conformity with applicable standards

YOUR ADVANTAGES

- > **An effective design, optimized in all aspects.** Thanks to our multidisciplinary capability, you benefit from a holistic approach that at once considers all dimensioning, electrical protection, and power quality issues.
- > **Optimally tuned for safety, reliability, and life span.** We tune your parameter settings to achieve optimal balance of all operational aspects that are important for your specific situation.
- > **Lowest total cost of ownership.** You obtain a design that balances investment costs with reliable predictions of operation costs, including inefficient use of energy, hidden costs of maintenance, safety risks, ageing, and incidents.

OPERATIONAL EXCELLENCE

Increase efficiency and prevent ageing of your network

How can you prevent interruptions, slow down ageing, and increase energy efficiency? And when an incident does occur, how do you find a quick and sustainable solution? The answer lies in an accurate view of your network's key parameters and in monitoring unexpected loads, currents and voltages, detecting power quality phenomena, and predicting potential safety risks. Laborelec's advice is well-founded with relevant and correct measurements, expert diagnoses, and field-tested recommendations.

FOR NEW AND/OR EXTENDED NETWORKS: DETAILED ASSESSMENT

The first step to higher network performance is obtaining an accurate picture of its true status. This is especially useful when initiating exploitation of new or changed networks. Laborelec assesses your electrical network and benchmarks it to standards and best practices. We can advise you on:

- > Compliance with national and international standards
- > Power quality levels inside and outside your network
- > Effectiveness of your electrical protection (safety and selectivity)
- > Energy transmission efficiency (eliminating dissipated power due to joule losses)
- > Dimensioning parameters

We provide you with a comprehensive report including calculation results and recommendations for improvements. This report is based on calculations and modelling with a tool that can simulate all types of industrial equipment, from any major manufacturer. We also take care of updating your safety documentation, a key factor in today's evermore-stringent legislative and regulatory climate.

OPTIMAL LIFESPAN: PERMANENT MONITORING

Permanent monitoring provides you with essential information to uncover unsuspected deviations in your network performance. Laborelec knows exactly what parameters to monitor in your specific situation. We are accredited to carry out a broad range of electrical measurements and have the appropriate high quality monitoring devices. However, we do not overwhelm you with meaningless data overload. We interpret the measurement results and provide you with useful expert analyses. You obtain a clear overview and feasible recommendations, tailored to your situation and budget constraints.



COMPLEX MEASUREMENTS AND MONITORING

Core competency

Be assured of proper measurements, conducted in the approved manner, and translated into meaningful conclusions.

HOW?

- > We listen to your problem. We do not try to sell you a one-size-fits-all measurement campaign.
- > We determine and define the most appropriate and most effective measurement strategy: the right measurements at the right time.
- > We conduct all measurements in the approved manner, with equipment that enables logging data at very high sampling frequencies.
- > We analyse the results and conduct in-depth calculations and/or simulations.

We conduct complex voltage, current, and power measurements in low, medium, and high voltage electrical networks and industrial plants. These include waveforms, Root-Mean-Square (RMS) values, harmonics, voltage imbalance between phases, frequency, power (P, Q, S, and D), Cos phi and power factor, flicker, and much more.

WHAT?

- > Root cause analysis
- > Short and long-term power quality monitoring
- > Online monitoring and trending
- > Electrical fingerprint of equipment (start currents, harmonic impedance, etc.)
- > Validation of simulation models
- > Performance monitoring of renewable energy sources

WHY LABORELEC?

- > Assured of the most effective measurement strategy, adapted to your precise situation
- > Correct interpretation of measurement results thanks to decades of on-site and advanced laboratory expertise
- > Certified and accredited for laboratory and on-site measurements, state-of-the-art measurement equipment, and cutting-edge calculation software



ACCURATE MODELLING OF COMPLEX NETWORKS

Core competency

Rely on models that are continuously approved and validated with genuine and meaningful data.

HOW?

We build and validate models of your network or plant and use the most advanced simulation tools available:

- > NEPLAN®, linked with MATLAB® and Simulink® for dynamic modelling
- > 3EI.bt®
- > VISION PowerNet

Based on reliable, non-generic, load profiles, we precisely and rapidly predict the electrical behaviour of even the most sophisticated and complex networks.

WHAT?

- > Design concept optimization and dimensioning
- > Impact prediction of changes in the internal electrical network and loads
- > Energy efficiency improvement (correct sizing of cables and components)
- > Electrical protection audit
- > Increasing effectiveness of measurement campaigns

WHY LABORELEC?

- > Precise and rapid simulation results, based on our own validated models and updated load profiles
- > Modelling of any type of industrial equipment from virtually any manufacturer or brand in general use
- > Comprehensive report with infractions and recommendations, underpinned by solid calculation methodologies

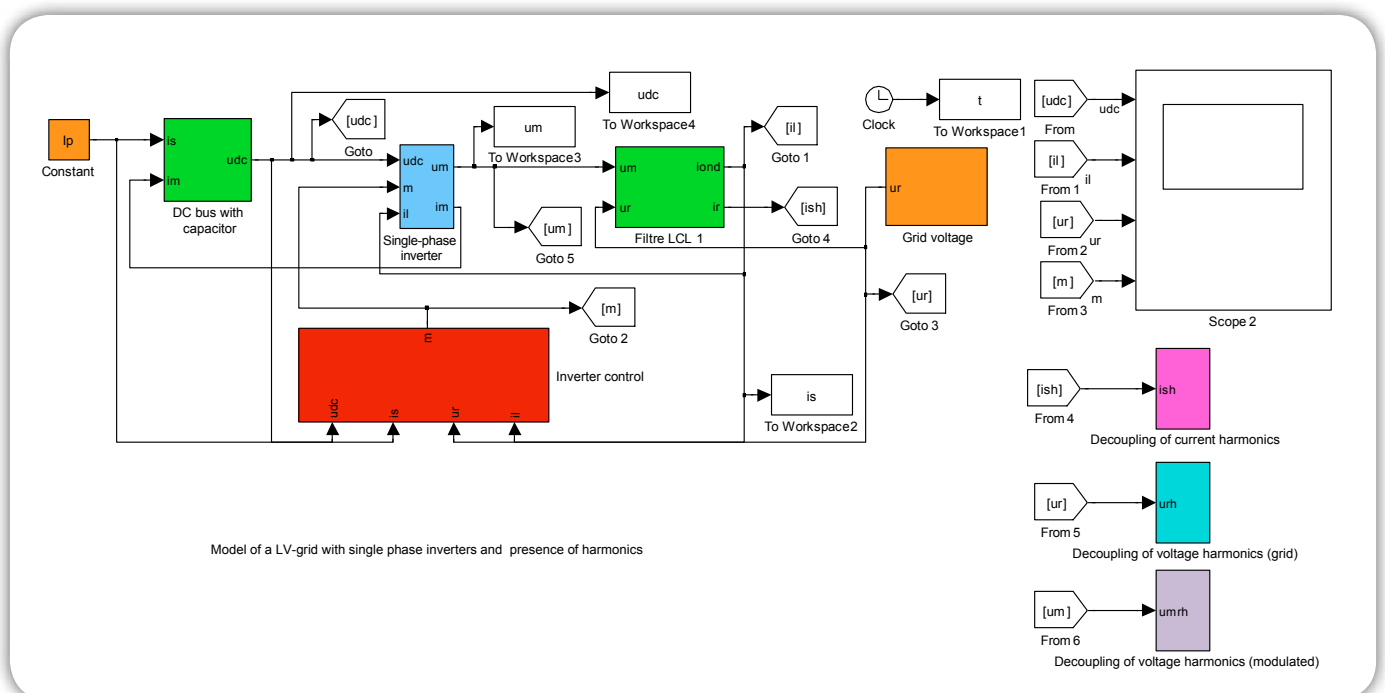

PROTECTION AND SELECTIVITY STUDIES

Core competency

Automated tuning software tools are sometimes unsatisfactory. Rely on the trained eye of experts with years of hands-on technical field experience.

HOW?

Laborelec tunes your protection parameters to the optimum balance between:

- > The safety of people and processes
- > The reliability of your network
- > The lifespan of your installation

We assess your protection scheme according to the highest safety standards and best practices:

- > I.E.C. (International standard)
- > AREI/RGIE (Belgian regulation)
- > NEN 1010 (Dutch standard)
- > NFC15-100 (French standard, UTE 15L-609 certified)
- > VDE (German standard)
- > RO 64-003 (CENELEC Busbar trunking standard)

We also advise you on achieving the appropriate selectivity of your security relays in order to ensure immediate isolation of a defective installation without unnecessarily switching off other productive portions of your network.

WHAT?

- > Design
 - New plants
 - Changes in internal electrical networks or loads
 - Purchasing protection equipment
- > Completion
 - Tuning parameter settings according to the highest safety and selectivity practices
- > Exploitation
 - Preventive selectivity study of electrical protection scheme
- > Trouble shooting
 - Root cause analysis
 - Evaluation of your protection strategy performance

WHY LABORELEC?

- > In-depth knowledge of all types of equipment, independent from manufacturers
- > Critical eye on manufacturer's defaults thanks to decades of experience with complex electricity grids
- > Advanced tools for precise and rapid optimization calculations

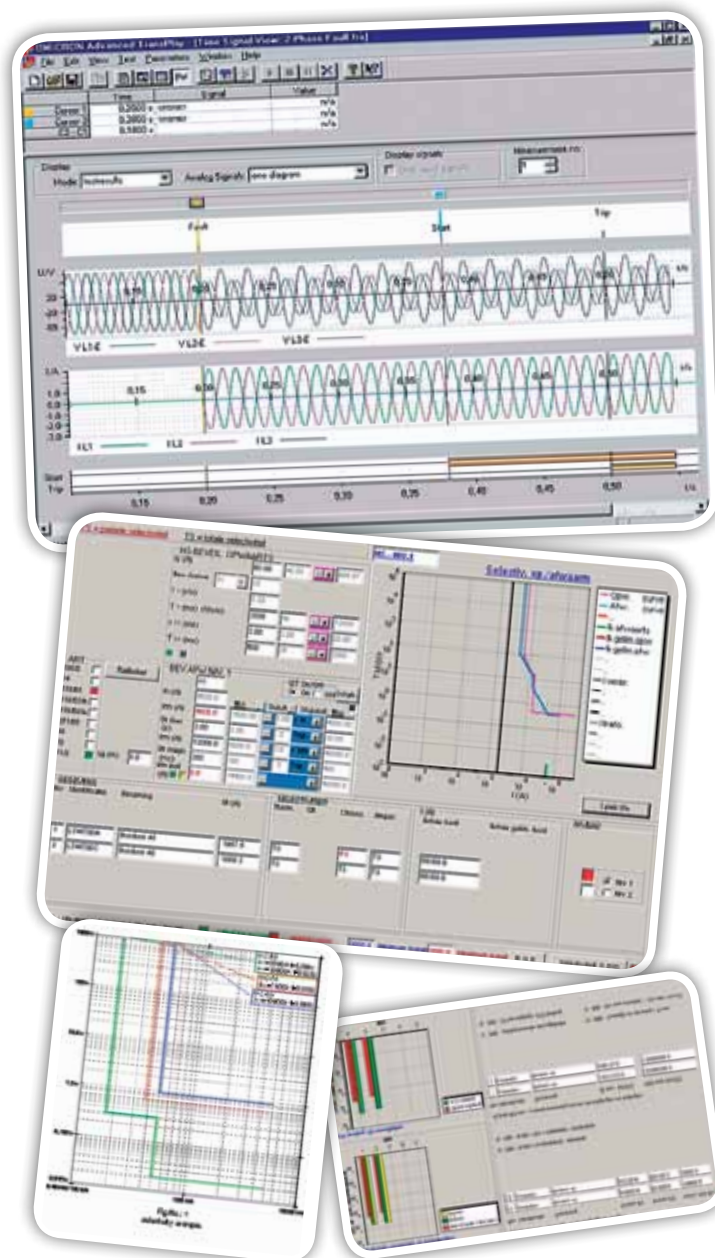

GRIDS OF THE FUTURE

Core competency

Discover a partner that combines a highly advanced level of research activities with real life day-to-day field experience.

HOW?

Laborelec advises on all aspects of the grids in our future:

- > Predicting the interaction between distributed energy resources (such as wind turbines, micro-cogeneration, photovoltaic systems, and electrical storage) and the grid
- > Assuring quality and security of supply
- > Keeping balancing costs under control
- > Demand side management (load balancing)
- > Intelligent electricity grids
- > Smart metering

Laborelec developed and patented the Demand Power Management System (DPMS), a proven method for dynamic load control in electrical networks:

- > We were the first to resolve the conflict between stable power supply and flexible energy use
- > We enable both the reduction of load during high-demand hours (peak shaving) and the shifting of peak loads to (lower cost) low-demand hours (peak shifting)
- > We successfully designed and implemented the world's first self-supporting, zero-emission, scientific research facility in Antarctica

WHAT?

- > New connections of distributed energy resources and modern applications (such as heat pumps and electric vehicles)
- > Remaining compliant with changing grid codes
- > Lowering your electricity bill (load balancing)

WHY LABORELEC?

- > Real field experience with future grid components
- > Advanced modelling tools and up-to-date load profiles for distributed energy resources
- > Vast experience with complex distribution networks



PROVEN METHODOLOGY

Tailored to your specific situation

To obtain operational excellence, you have to be able to rely on the unbiased and neutral advice of an experienced partner. You must be certain that the measurements conducted by your partner are appropriate, that continuity and safety is guaranteed during on-site measurement campaigns, and that they are able to tackle complex, multidisciplinary electricity problems.

DEDICATED TO YOUR PROBLEMS

Our experts approach your questions and problems with an open mind. They listen carefully to your story and map your specific situation in an appropriate level of detail.

INDEPENDENT AND NEUTRAL

We are independent from all manufacturers. The wide range of technical disciplines and measurement techniques we have mastered enable us to choose the most appropriate approach to solving your problems.

MULTIDISCIPLINARY TEAM BUT A SINGLE POINT OF CONTACT

You need a sustainable solution, not a fragmented dossier of hypotheses. Laborelec assigns a single point of contact, who calls in the right in-house experts from a wide variety of disciplines. They work as a team to achieve an immediate and long-lasting solution.

GUARANTEED ON-SITE SAFETY

All of our on-site measurements and interventions follow strict QA and VCA safety standards. We guarantee correct and safe measurements at all voltage levels.

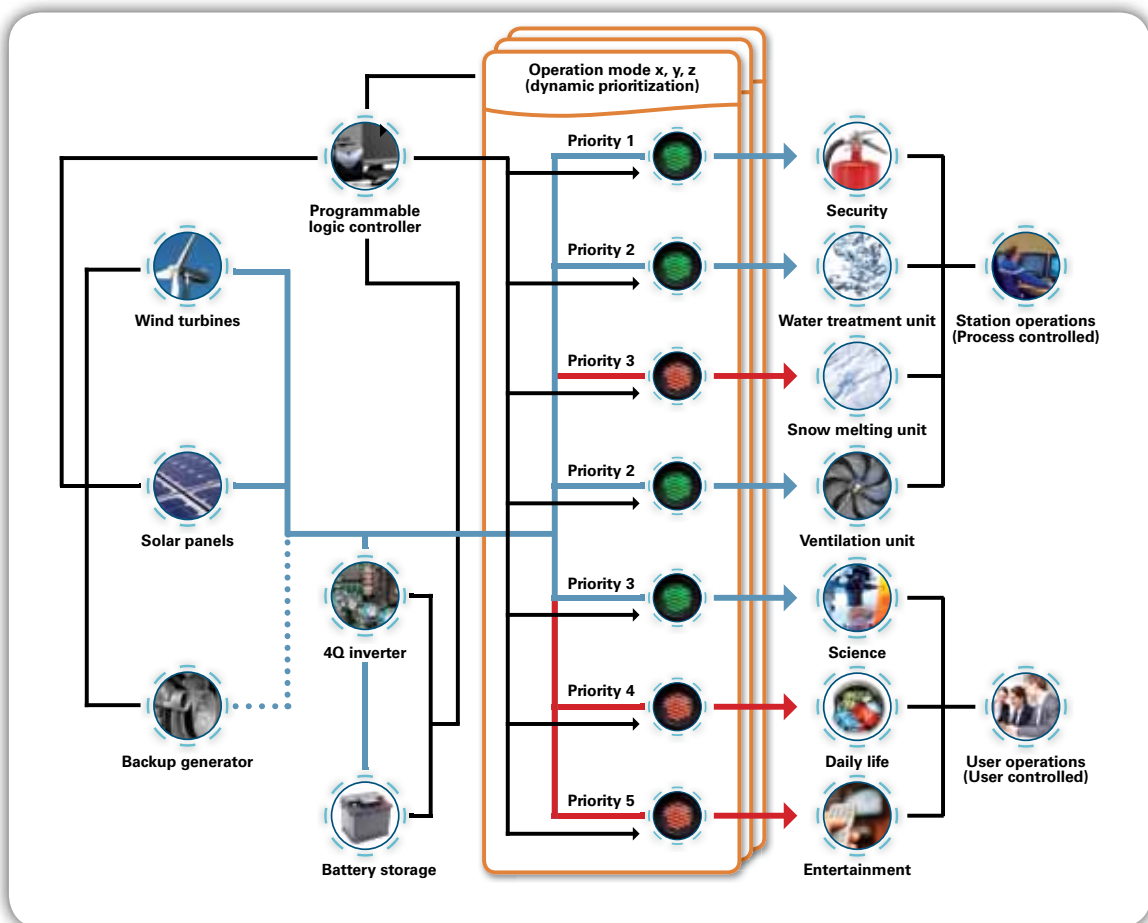

CERTIFIED AND RECOGNIZED

Only a certified laboratory can guarantee quality tests. Our measurements, calculations, and analyses both on-site and in the laboratory are ISO-certified.



CERTIFICATE OF APPROVAL

This is to certify that the Quality Management System of:

LABORELEC
Linkebeek, Belgium

has been approved by Lloyd's Register Quality Assurance to the following Quality Management System Standards:

ISO 9001 : 2008

The Quality Management System is applicable to:

Electrical system measurements :
Analysis of different electro technical problems through means of an extensive range of measurement equipment for currents and voltages and this on high and medium voltage networks. Accurate measurements and storage of currents and voltages to be able to execute detailed calculations in the field of power quality, electrical powers (active, reactive, apparent), transients (inrush currents, switching phenomena, protections, ...) and predicative maintenance analysis (motors, transformers, power electronic applications, ...).
Further development and constant improvement of new electrical measurement systems with regard to these activities to be ready for the challenges of tomorrow.

Approval Certificate No:	Original Approval	:	7 December 2005
ANT06102	Current Certificate	:	20 July 2010
	Certificate Expiry	:	31 December 2011

Issued by: Lloyd's Register EMEA, Antwerp Office
for and on behalf of Lloyd's Register Quality Assurance Limited



001

This document is subject to the provision on the reverse
Rijnkaai 37, 2000 Antwerp, Belgium, Company Number 0860.936.663
This approval is granted only in accordance with the LRQA assessment and certification procedures and monitored by LRQA.
The use of the UKAS Accreditation Mark indicates Accreditation in respect of these activities covered by the Accreditation Certificate Number 001.

CASES

SEAMLESS INTEGRATION OF NEW GENERATION UNIT

Total Petrochemicals integrated a new cogeneration unit into their site in Feluy, Belgium. Laborelec provided recommendations to ensure seamless integration of the unit into the existing internal and external electrical network:

- > Well-founded proof of compliance with the Belgian grid code
- > Retuning the protection selectivity parameters of the entire network
- > Confirmation that the dimensioning was satisfactory to deal with a short circuit or overload

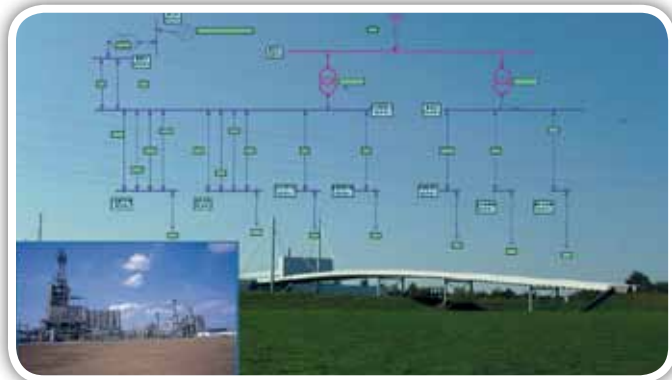

SELECTIVITY STUDY FOR COMPLEX AND UNUSUAL GRID

Grid operator Energie Electrique en Nouvelle-Calédonie (EEC) improved the selectivity of the electrical grid of Nouméa, the capital of New Caledonia. Since the network is large and complex, with particularities concerning selectivity, EEC relied on Laborelec's experts to study and tune the protection relay parameters.



PREDICTING THE INTERACTION BETWEEN DECENTRALIZED GENERATION AND THE GRID

Laborelec developed models to simulate the interaction between wind turbine response and grid incidents. We analyzed the impact of voltage dips and frequency variations on wind turbine performance, and validated the results and models with on-site measurements. We also investigated and simulated the potential effects of wind turbines on the grid. Thanks to the study Laborelec can provide profound advice to industries and grid operators on the installation of new decentralized generation units.

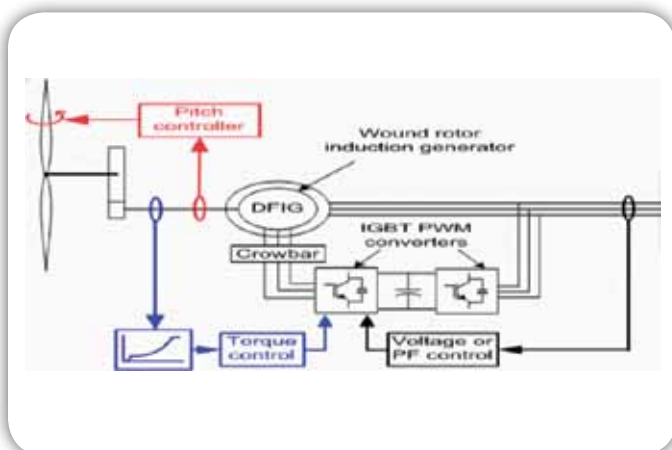

IMPROVING SYNTHETIC LOAD PROFILES WITH SMART METERING DATA

When dimensioning low and medium voltage grids, operators use Synthetic Load Profiles (SLPs) to simulate and predict the electricity consumption of households. Laborelec proved that smart metering data significantly improve SLPs' capacity to deal with modern household loads. As a next step, we are integrating loads such as heat pumps, micro-CHP, and photovoltaic (PV) units into the SLPs.

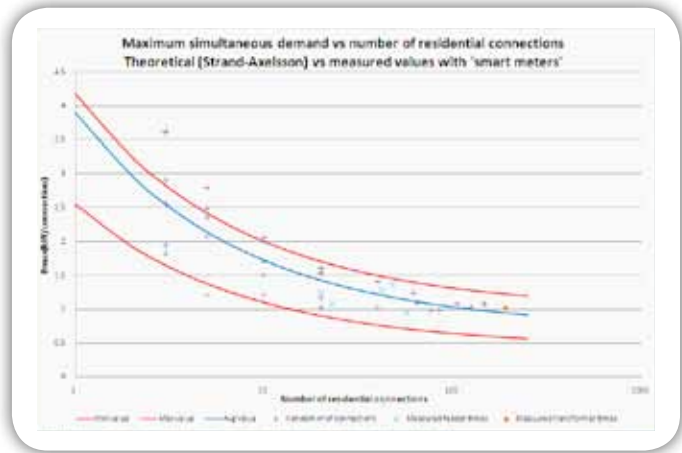

ASSURING COMPLIANCE WITH SPECIFIC SAFETY STANDARDS

For the construction of a new state-of-the-art hospital, Laborelec was asked to support the engineering office in the dimensioning of the electrical installation on medium and low voltage. Laborelec redesigned the entire concept of the electrical network, making it compliant with the applicable safety standards. Special attention was drawn to a technical note (T013) that imposes extra design rules for the safe installation and operation of advanced medical equipment.





FIVE REASONS FOR YOU TO CHOOSE LABORELEC

- > One-stop centre for all of your energy-related needs
- > More than 40 years of experience
- > Increased profitability of your installations
- > Independent and confidential advice
- > Internationally recognized and certified laboratory

The Technical **Competence Centre**
In **energy processes** and **energy use**
From **innovation** to **operational assistance**

Contact Laborelec Electrical Power Systems, Analyses and Concepts

Sven Kerremans

sven.kerremans@laborelec.com

T. +32 2 382 03 07

Laborelec Belgium

Rodestraat 125
1630 Linkebeek

T. +32 2 382 02 11

F. +32 2 382 02 41

RPR/RPM Brussels 0400.902.582

BTW/TVA BE 0400 902 582

www.laborelec.com

info@laborelec.com

Laborelec the Netherlands

Amerikalaan 35
6199 AE Maastricht-Airport

T. +31 43 36 75 391

Laborelec Germany

Bromberger Strasse
42281 Wuppertal

T. +49 202 250 27 13



LABORELEC
GDF SUEZ